

RAIL BRAKES

OCTOBER 2009

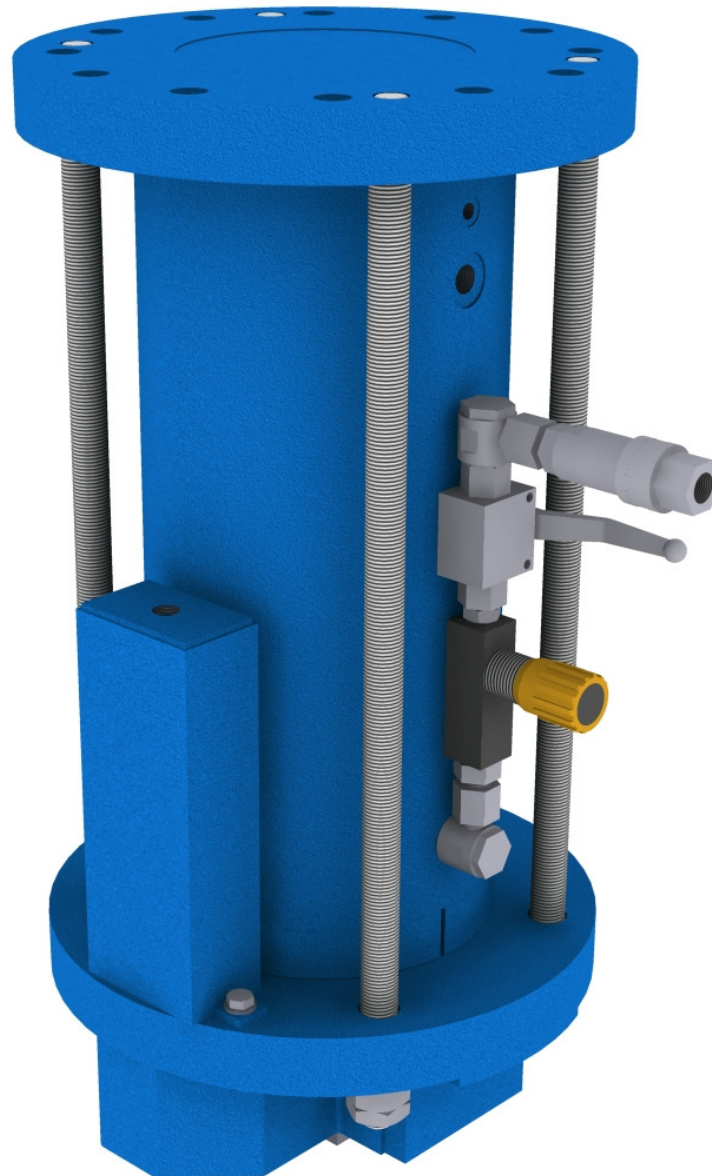

CATALOGUE "TP"



Rima S.r.l.
Via Fermi 255 – 21042 Caronno Pertusella (Va) Italy
Phone: +39 02 9650694 – Fax +39 02 9657860
E-mail: rima@rimagroup.com



WWW.RIMAGROUP.COM

DESCRIPTION

• Utilization and functioning

Rail brakes, suitable for medium forces from 20 to 300 kN (securing cranes against the wind force) work pressing down on the top of rail by disk springs. Brakes are hydraulically released. Usual parking utilisation requires a few closing / opening cycles per day.

The design friction coeff. is 0,5.

They are usually installed in the middle of crane gantry travel (One per crane corner).

• Advantages

- No affected by rail conditions
- Suitability of application with rail embedded into pave. (Rail channel filled)
- Low price

• Disadvantages

Generation of vertical forces (it is necessary to check the effect of vertical forces on crane and run-way).

• Technical features

- Installation: upper flange;
- Vertical float = see drawings;
- Horizontal float = ± 25 mm (could change depending on rail type)
- Opening time (consent to gantry operation) = see drawings;
- Closing time = adjustable from 4 to 12 s;

On request these values can be modified.

• Friction coefficient (TUV certified)

Design holding force is calculated with a friction coeff. = 0,5 (certified by TUV German register).

With new braking shoes the friction coeff in the worst condition is = 0,59.

This value decreases with wear of shoes.

The braking shoes are to be replaced when the 0,5 value of friction coefficient is reached (Detailed instructions are into Operation and Maintenance Manual).

OPERATING

• Opening of rail brakes

Operated by the hydraulic unit is obtained:

- Starting the electric motor
- Energizing the electro-valve

A suitable inductive limit switch gives the signal of "brake open" and allows the operation of gantry travel.

Then a pressure switch calibrated at higher value stops the pump motor.

In case small leakages should cause a pressure decrease, the pressure switch would start the pump motor restoring the correct pressure, without stopping the crane.

• Closing of rail brakes

The closing of rail brakes is obtained by de-energizing the electrovalve.

The oil flows to hydraulic unit and the rail brake is closed by the springs.

The closing time is controlled by means of a flow regulator valve (installed directly on the brake to work also in case of hose braking), that generate a delay to allow crane stop before brake closure.

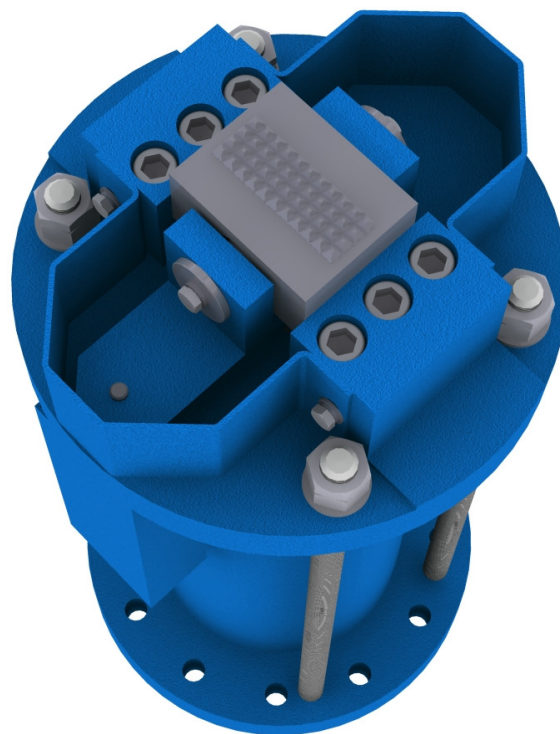

COMPOSITION

The brake force on the top of the rail is generated by the disc springs inside the rail brake.

Easy replaceable braking shoes made in 39NiCrMo4, knurled and quenched are mounted on spherical joint.

The braking shoes are suitable to work on rail that have the upper surface flat or curved. The jointed side is made in C40 tenifered. Piston rod of rail brake is C40 quenched and tempered and large-thickness chrome-plated. An inductive limit-switch indicates "brake open". A G3/8" hole is at the upper side of brake body for the connection to the oil tank to keep always springs in oil bath (it increases the efficiency and life of springs). A G3/8" hole is given (for the connection to the pump) to:

- Flow control valve for calibration of closing time (pre-calibrated at workshop at the requested value). This time does not change even in case of breakage of flexible hose.
- Ball valve, necessary to keep the brake open (under pressure) even without hydraulic unit. More over this valve is necessary to open the quick coupling under pressure.
- Quick coupling necessary to connect the brake to hand pump (supplied upon request). Through this way it is possible, in emergency, to open the brake even if the hydraulic unit cannot work.

• *Hydraulic Unit (see SCI-TP-01)*

It is suitable for sea-environment, completely assembled, wired to terminal box IP55 and flushed (acc. NAS 9).

Cover in carbon steel with hinged door.

• *Emergency manual opening device*

By hand pump that can be supplied loose (with tank and cock) or assembled on the hydraulic unit (according to client request). It is suggested the loose solution because one hand pump can be used to open more brakes. It can be operated even in case breakage of pipe connecting to hydraulic unit.

• *Standard painting*

Total thickness : 210 micron.

- Surfaces preparation: Sandblasting SA 2 1/2.
- 1° Coat: Moist curing inorganic two-component zinc primer. Consists on complex ethyle silicate and zinc dust in high rate (>86% in dry film). Thickness = 70/80 micron
- 2° Coat: Two-component epoxy-polyamide primer and undercoat with zinc phosphate and micaceous iron oxide. Thickness = 80/90 micron
- 3° Coat: Two-component aliphatic acryl-urethane based paint no yellowing. Reacoatable for long time. Thickness = 60/70 micron

Final colour: Standard RIMA RAL 5019.

• *Fluids for normal temperatures*

Hydraulic oil: ISO VG 15.

ELECTRIC CONTROL UNIT

It is usually foreseen by the crane manufacturer by means of relays or PLC. On request, it can be supplied on plate or in a box (IP 55).

Here after is illustrated the scheme we suggest (SCE-TP-01), which foresees the use of a suitable temporised relay. This relay is necessary to signal possible malfunctions in the hydraulic unit (for ex. oil deficiency or breakages of some hydraulic or electric components). Through this solution, temperature and level switches are not needed.

The logic control of the rail clamps closing is established by the customer.

The rail clamps are usually closed at the end of the crane work, or on signal of a suitable anemometer which signals that the wind speed is higher than the max. allowed speed.

The signal of closure of the rail clamp must be put under a timer to achieve an adjustable electric delay.

As the electrovalve has to be always excited, the magnet must be in direct current; if the customer wants to feed the coil valve with alternated current, a suitable rectifier it is supplied.

RAIL

Braking shoes of our rail clamp have been designed to work on rails commonly on the market whose hardness is between 200 and 270 HB ($\sigma = 700$ to 900 N/mm²). The certification of TUV are referred to above given values of rail hardness.

In case of different values we must be informed at order, Because this could affect the rail clamp functioning.

TESTING

All rail brakes are tested to check the springs force.

DOCUMENTATION

The documentation is worded according to EG (89/392/EWG) and Euro- EN 292-1/2; 1991 D rules.

- Use and Maintenance Manual
- Execution according to rules
- Over all dimension drawings
- Hydraulic and electric schemes
- Suggested spare part list
- Test Certificate
- Material certificated (EN 10204-2.1) for all main parts.

Documentation in Italian or English on cd-rom.



Rima S.r.l.

Via Fermi 255 – 21042 Caronno Pertusella (Va) Italy

Phone: +39 02 9650694 – Fax +39 02 9657860

E-mail: rima@rimagroup.com



WWW.RIMAGROUP.COM

REMOVAL

Brake it's easy to remove from the crane in any condition.

It is foreseen a mechanical device that allows a manual opening also in case spring compression through hydraulic unit or hand pump would be impossible for example due to internal seals braking.

WARRANTY

12/18 months

Warranty is subject to the following conditions:

- A) The electric diagram is made accordingly to the scheme we suggest (SCE-TM-01) or is made accordingly to a scheme designed by client but in any case approved by us.
- B) All maintenance procedures described in the manual provided with the supply are observed. In particular must be strictly observed the rules relevant to cleanliness and filters replacement.

In case one or more of above conditions should not be respected, the guarantee will be considered not valid.

EXECUTIONS

• *Normal execution*

- Working temperature: $-20^{\circ} \div +40^{\circ}$;
- Environment: marine;
- Connection: with one side flange;
- Emergency manual opening device (with hand pump supplied separated);
- Hydraulic unit supplied separately from rail brakes, provided with terminal box and suitable to operate with one or more rail brakes; without oil;
- Hydraulic unit with connection box;
- Suitable for rail with flat or curved upper surface (to be advised at order);
- Inductive limit switch for signals "brakes open".
- Removal emergency device.

• *Special execution (upon request with extra-price)*

- Working temperature different from standard;
- Manufacturing according Q.C.P. different from our standard (nuclear plants or special application);
- Dynamic braking;
- Suitability to double rail;
- Electrical board (on plate or box IP55);
- Pressure switch to signal "brakes open" (instead of limit switch);
- Installation between very close boogies (approx. 100 mm);
- Hydraulic unit with oil

- Documentation language out of standard
- Certificates of materials according to EN 10204-2.2, EN 10204-3.1 or EN 10204-3.2 for main components

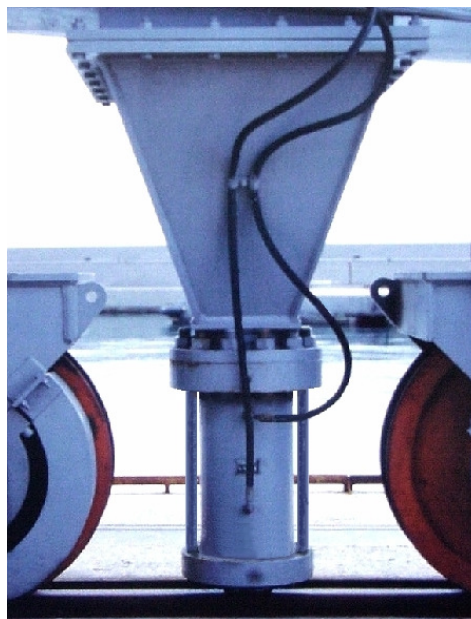

• *Execution with external cylinder*

Special version with levers. In this case there is a cylinder separated from disc spring block. It allows to replace a damaged cylinder in a short time without disassemble the brake from the crane



Rima S.r.l.

Via Fermi 255 – 21042 Caronno Pertusella (Va) Italy

Phone: +39 02 9650694 – Fax +39 02 9657860

E-mail: rima@rimagroup.com



WWW.RIMAGROUP.COM

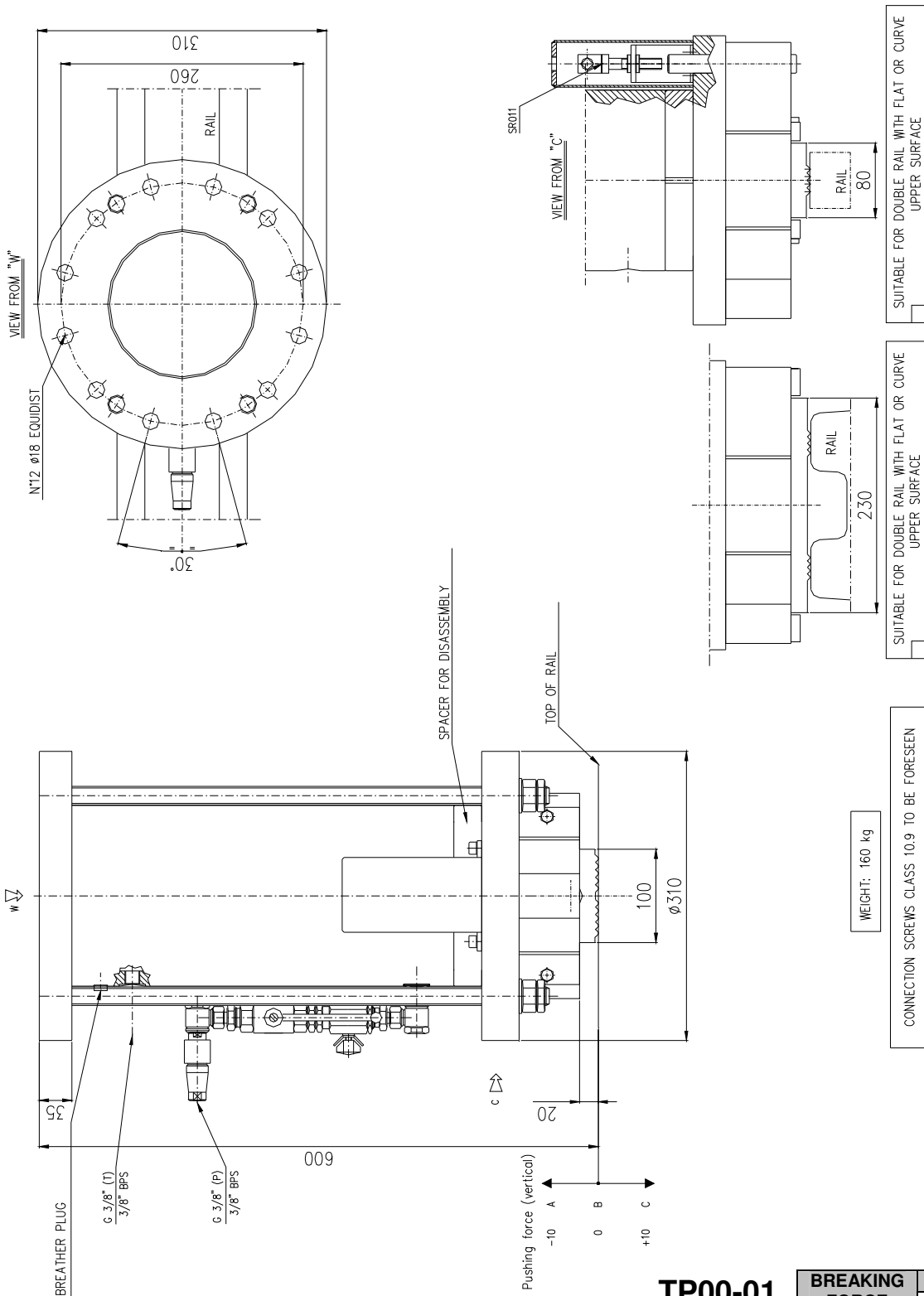

BRAKE TYPE	TP00-01 BREAKING FORCE	UPWARD FORCE		
		A	B	C
TP00-0040-01	40 kN	106 kN	80 kN	50 kN
TP00-0045-01	45 kN	135 kN	90 kN	39 kN
TP00-0050-01	50 kN	144 kN	100 kN	50 kN
TP00-0055-01	55 kN	153 kN	110 kN	62 kN
TP00-0060-01	60 kN	161 kN	120 kN	73 kN
TP00-0065-01	65 kN	170 kN	130 kN	84 kN
TP00-0070-01	70 kN	180 kN	140 kN	96 kN
TP00-0075-01	75 kN	189 kN	150 kN	107 kN
TP00-0080-01	80 kN	198 kN	160 kN	118 kN
TP00-0085-01	85 kN	210 kN	170 kN	120 kN



Rima S.r.l.
 Via Fermi 255 – 21042 Caronno Pertusella (Va) Italy
 Phone: +39 02 9650694 – Fax +39 02 9657860
 E-mail: rima@rimagroup.com



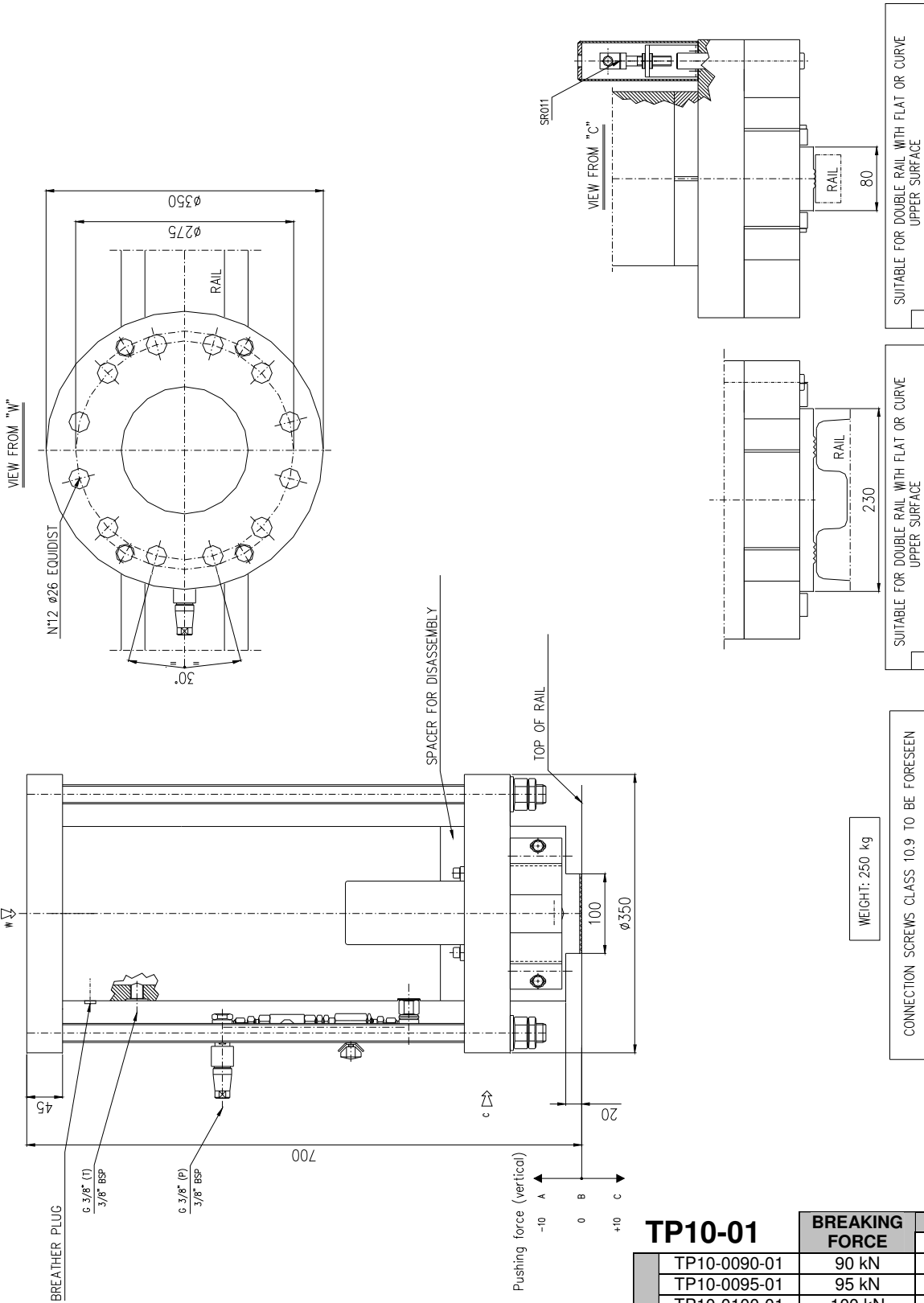

CONNECTION SCREWS CLASS 10.9 TO BE FORESEEN

WEIGHT: 250 kg

TP10-01

BRAKE TYPE	BREAKING FORCE	UPWARD FORCE		
		A	B	C
TP10-0090-01	90 kN	250 kN	180 kN	105 kN
TP10-0095-01	95 kN	260 kN	190 kN	116 kN
TP10-0100-01	100 kN	268 kN	200 kN	126 kN
TP10-0105-01	105 kN	278 kN	210 kN	137 kN
TP10-0110-01	110 kN	287 kN	220 kN	140 kN
TP10-0115-01	115 kN	323 kN	230 kN	130 kN
TP10-0120-01	120 kN	333 kN	240 kN	140 kN
TP10-0125-01	125 kN	342 kN	250 kN	151 kN
TP10-0130-01	130 kN	352 kN	260 kN	162 kN
TP10-0135-01	135 kN	361 kN	270 kN	173 kN
TP10-0140-01	140 kN	371 kN	280 kN	183 kN
TP10-0145-01	145 kN	380 kN	290 kN	194 kN



Rima S.r.l.
 Via Fermi 255 – 21042 Caronno Pertusella (Va) Italy
 Phone: +39 02 9650694 – Fax +39 02 9657860
 E-mail: rima@rimagroup.com



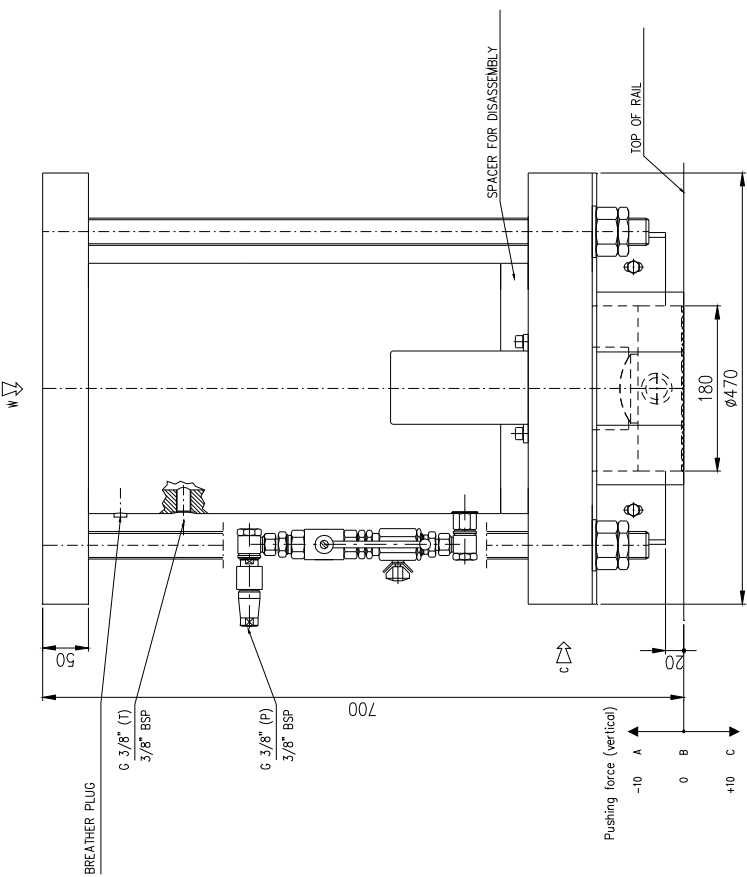
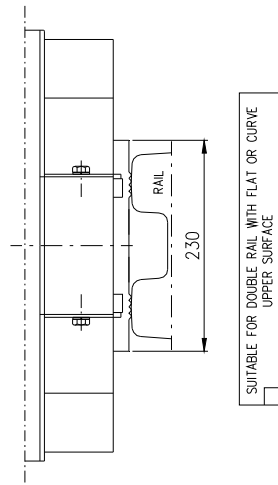
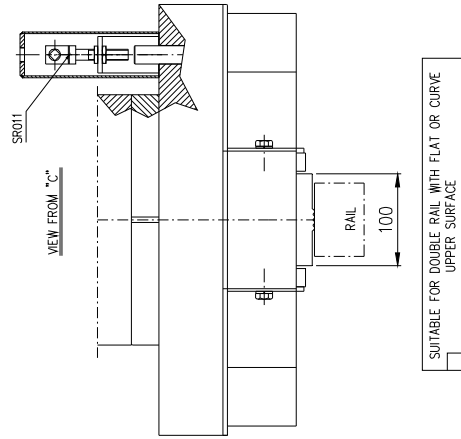
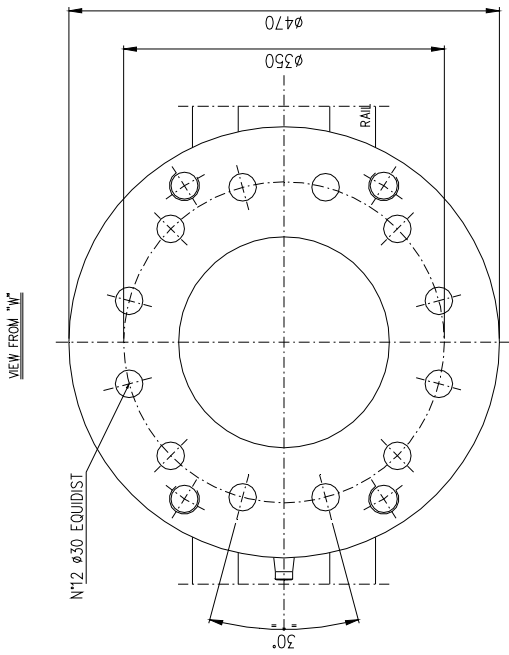

WEIGHT: 420 kg

CONNECTION SCREWS CLASS 10.9 TO BE FORESEEN

BRAKE TYPE	TP20-01	BREAKING FORCE	UPWARD FORCE		
			A	B	C
	TP20-0150-01	150 kN	400 kN	300 kN	190 kN
	TP20-0155-01	155 kN	405 kN	310 kN	205 kN
	TP20-0160-01	160 kN	415 kN	320 kN	215 kN
	TP20-0165-01	165 kN	425 kN	330 kN	225 kN
	TP20-0170-01	170 kN	435 kN	340 kN	235 kN
	TP20-0175-01	175 kN	510 kN	350 kN	175 kN
	TP20-0180-01	180 kN	520 kN	360 kN	185 kN
	TP20-0185-01	185 kN	530 kN	370 kN	195 kN
	TP20-0190-01	190 kN	540 kN	380 kN	205 kN
	TP20-0195-01	195 kN	550 kN	390 kN	220 kN
	TP20-0200-01	200 kN	560 kN	400 kN	230 kN



Rima S.r.l.
 Via Fermi 255 – 21042 Caronno Pertusella (Va) Italy
 Phone: +39 02 9650694 – Fax +39 02 9657860
 E-mail: rima@rimagroup.com



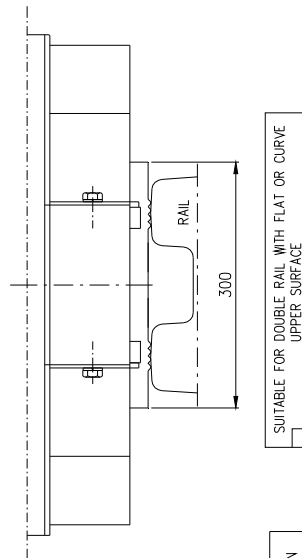
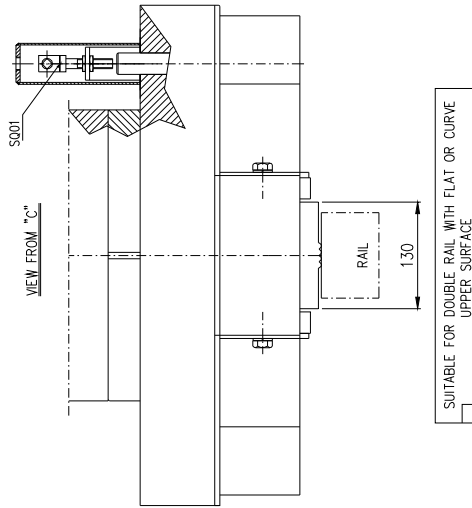
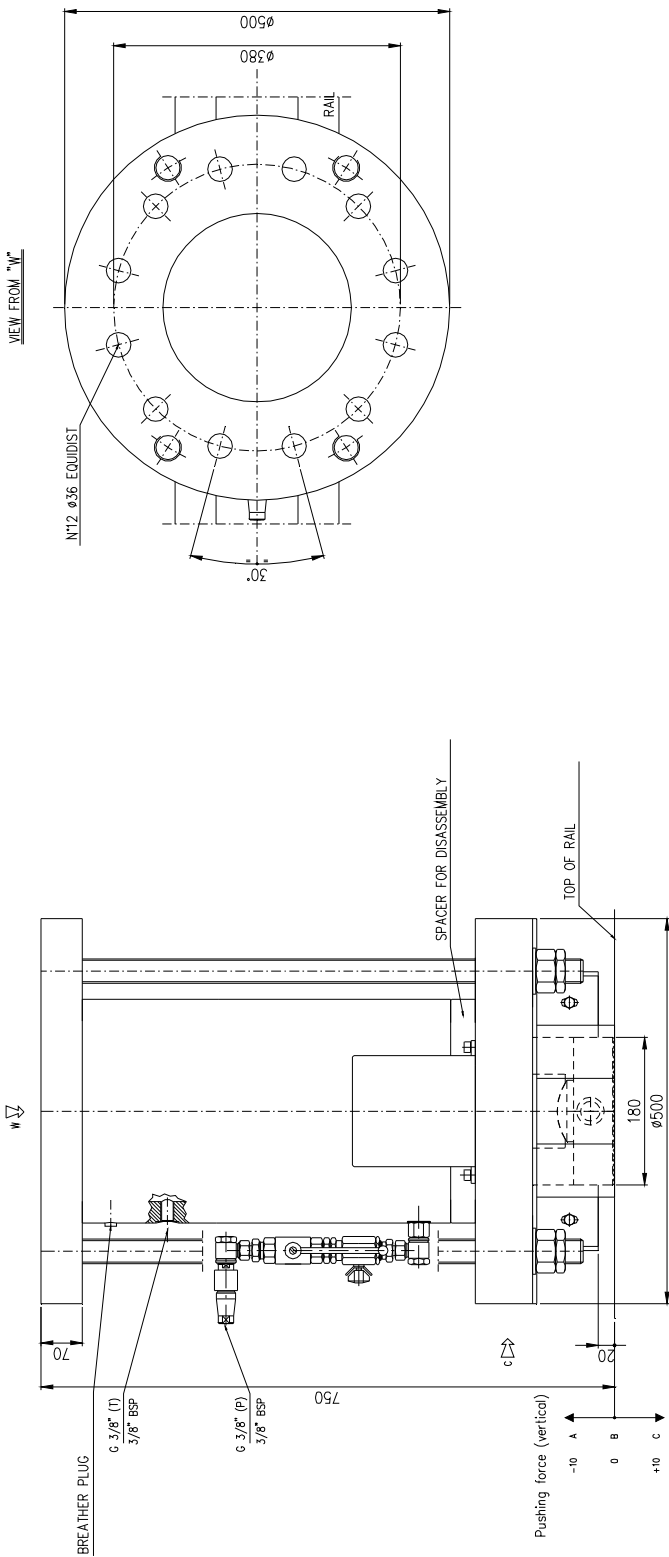

WEIGHT: 560 kg

CONNECTION SCREWS CLASS 10.9 TO BE FORESEEN

TP30-01

BRAKE TYPE	BREAKING FORCE	UPWARD FORCE		
		A	B	C
TP30-0205-01	205 kN	578 kN	410 kN	229 kN
TP30-0210-01	210 kN	588 kN	420 kN	240 kN
TP30-0215-01	215 kN	597 kN	430 kN	251 kN
TP30-0220-01	220 kN	606 kN	440 kN	261 kN
TP30-0225-01	225 kN	616 kN	450 kN	272 kN
TP30-0230-01	230 kN	625 kN	460 kN	283 kN
TP30-0235-01	235 kN	635 kN	470 kN	294 kN
TP30-0240-01	240 kN	644 kN	480 kN	304 kN
TP30-0245-01	245 kN	653 kN	490 kN	315 kN
TP30-0250-01	250 kN	663 kN	500 kN	326 kN



Rima S.r.l.
 Via Fermi 255 – 21042 Caronno Pertusella (Va) Italy
 Phone: +39 02 9650694 – Fax +39 02 9657860
 E-mail: rima@rimagroup.com



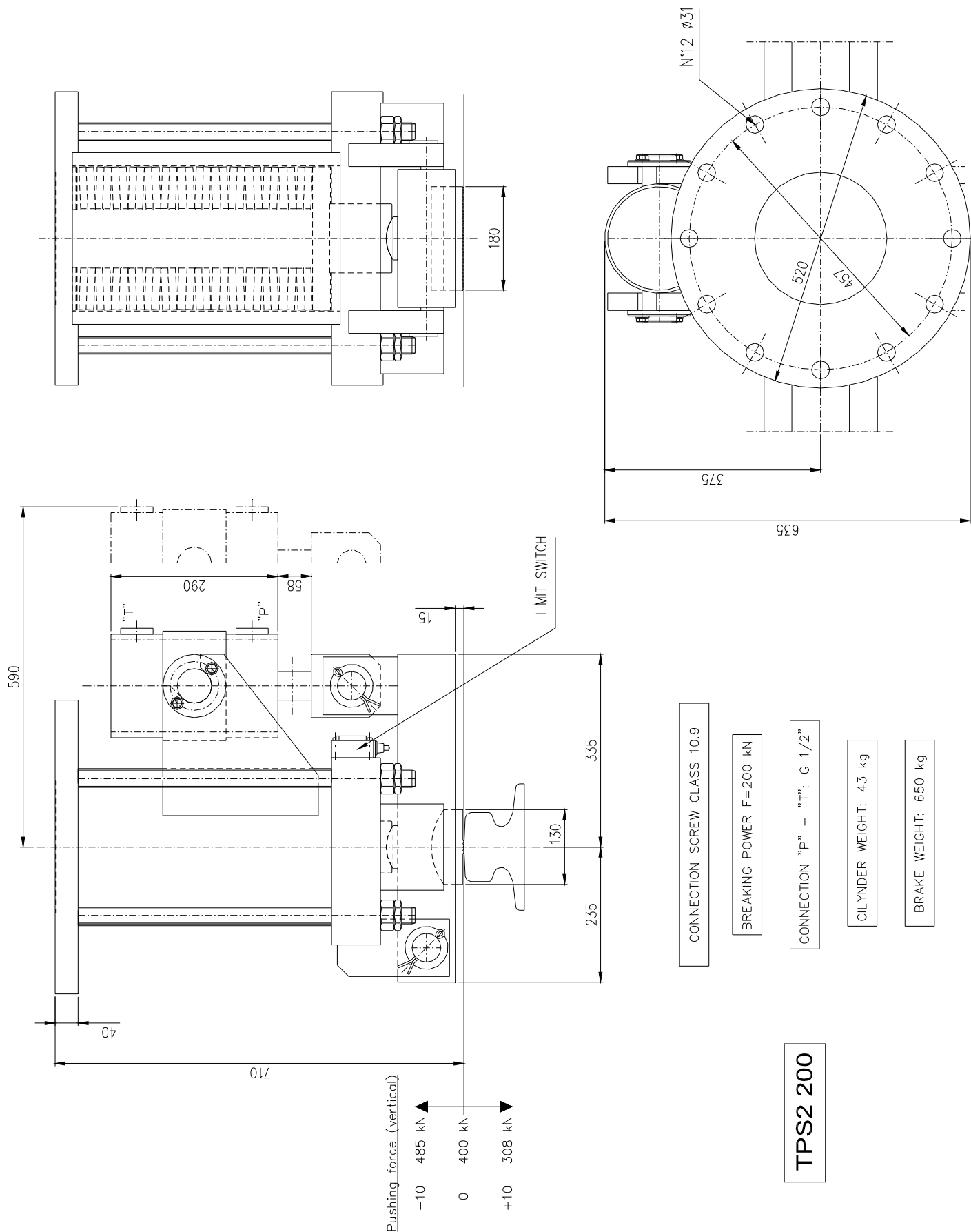

Rima S.r.l.
 Via Fermi 255 - 21042 Caronno Pertusella (Va) Italy
 Phone: +39 02 9650694 - Fax +39 02 9657860
 E-mail: rima@rimagroup.com



WWW.RIMAGROUP.COM

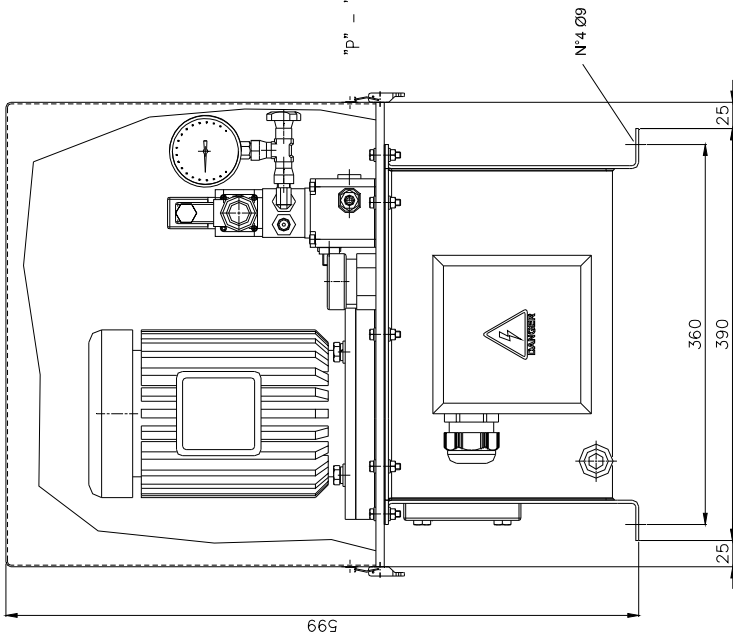
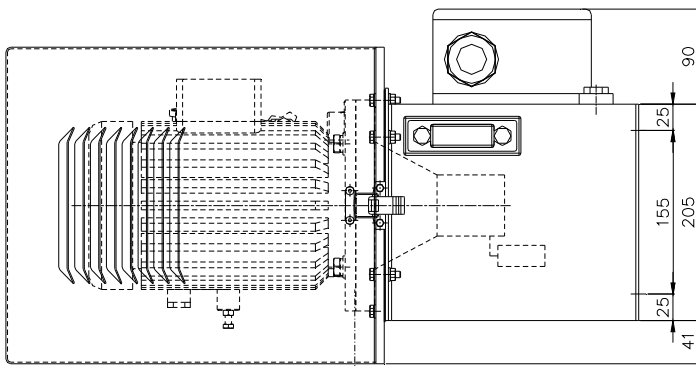
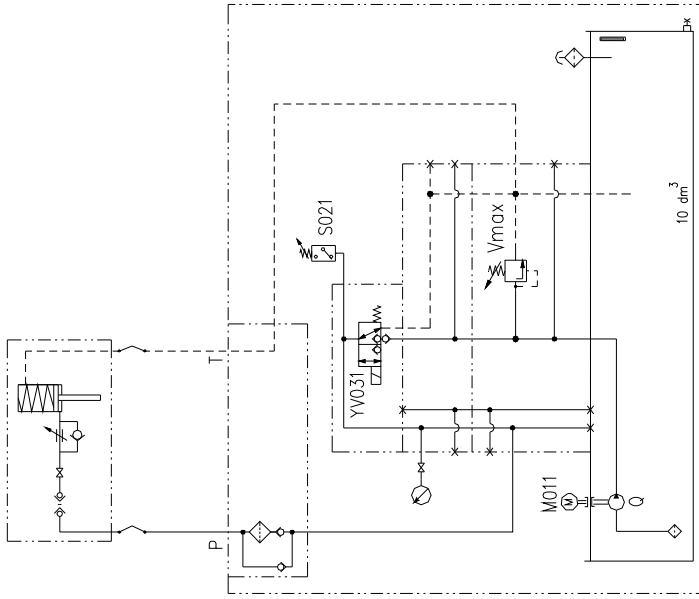

WEIGHT 60 kg
without oil

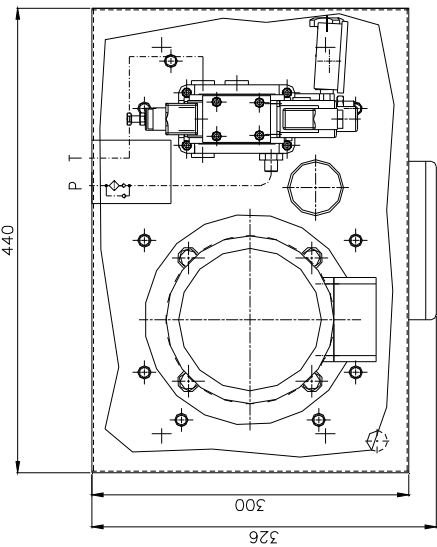

TYPE	* M011 (kW)	Q (l/min)	Vmax (MPa)	S021 (MPa)	* YV031	P-T	OPENING TIMES (s) (suitable for one brake)			
							TP-00-01	TP-10-01	TP-20-01	TP-30-01
SCI-TP10-5-01	1.5 400V-50Hz	5	21	19-18	24V DC-30W	G3/8"	2	2.5	4	5.5
* = OTHER FEEDING TENSIONS ON REQUEST							OTHER TIMES ON REQUEST			



Rima S.r.l.
Via Fermi 255 – 21042 Caronno Pertusella (Va) Italy
Phone: +39 02 9650694 – Fax +39 02 9657860
E-mail: rima@rimagroup.com



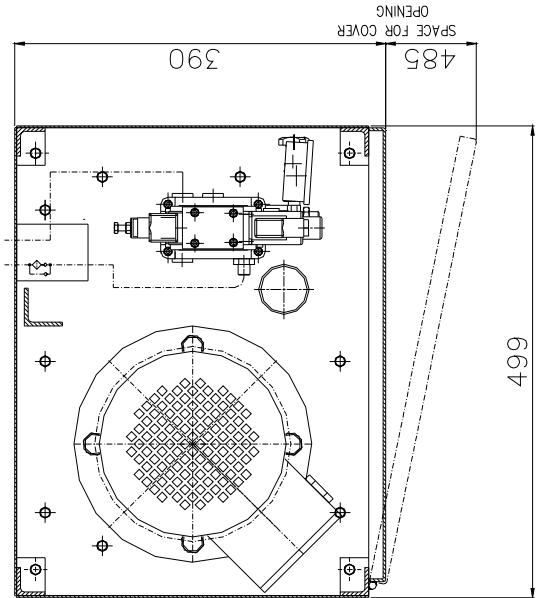
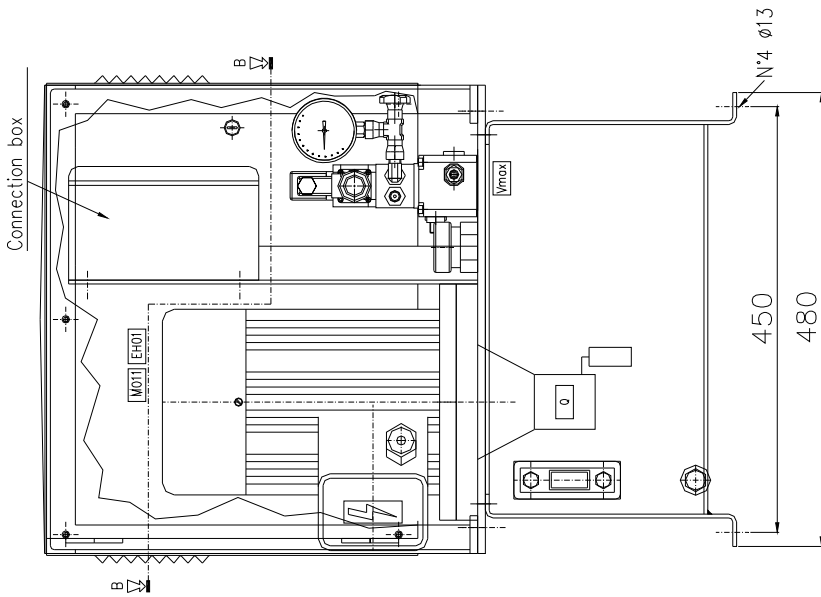

SEZ B.B.B

WEIGHT 75 kg
without oil

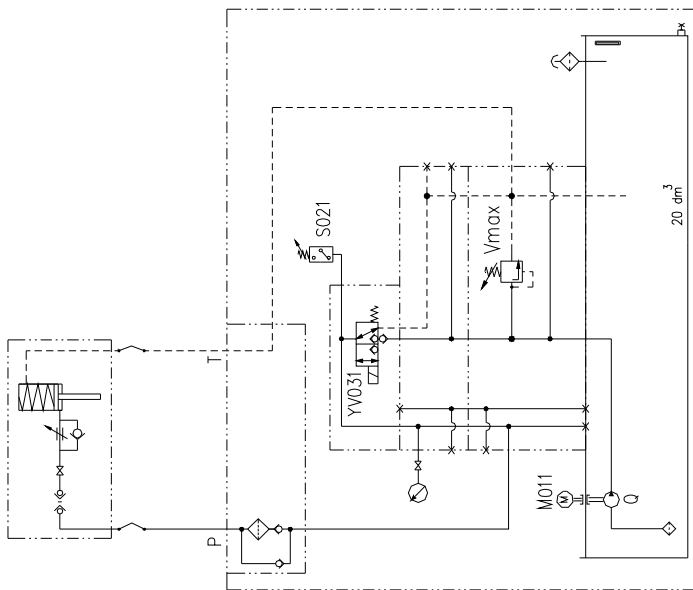
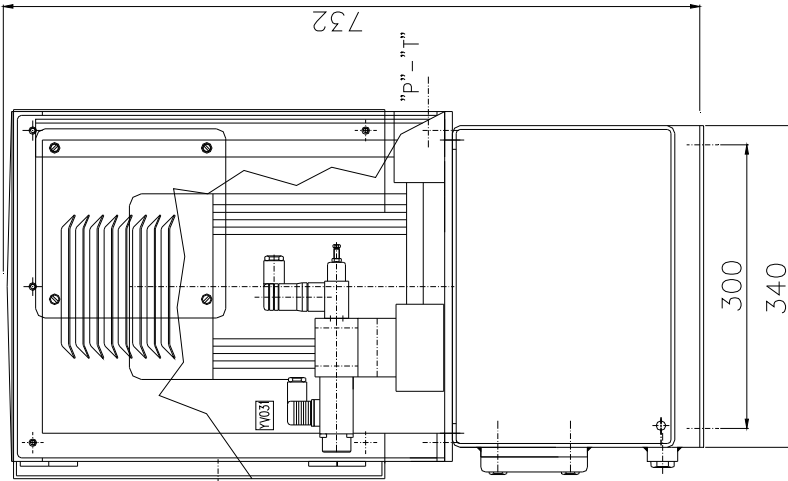

TYPE	* M011 (kW)	Q (l/min)	Vmax (MPa)	S021 (MPa)	*	P-T	OPENING TIMES (s) (suitable for one brake)			
							TP-00-01	TP-10-01	TP-20-01	TP-30-01
SCI-TP-20-7.5-S-01	3	7.5	21	19-18	24V DC-30W	G3/8"	1.4	1.7	2.7	3.7

* = OTHER FEEDING TENSIONS ON REQUEST

OTHER TIMES ON REQUEST



Rima S.r.l.
Via Fermi 255 – 21042 Caronno Pertusella (Va) Italy
Phone: +39 02 9650694 – Fax +39 02 9657860
E-mail: rima@rimagroup.com



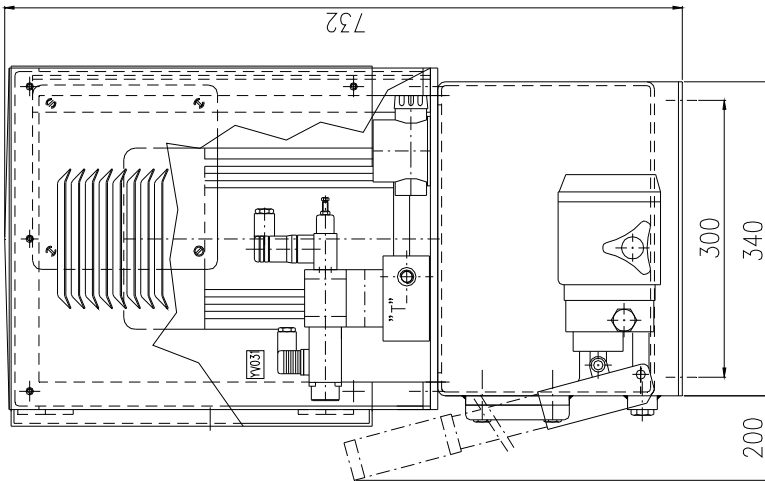
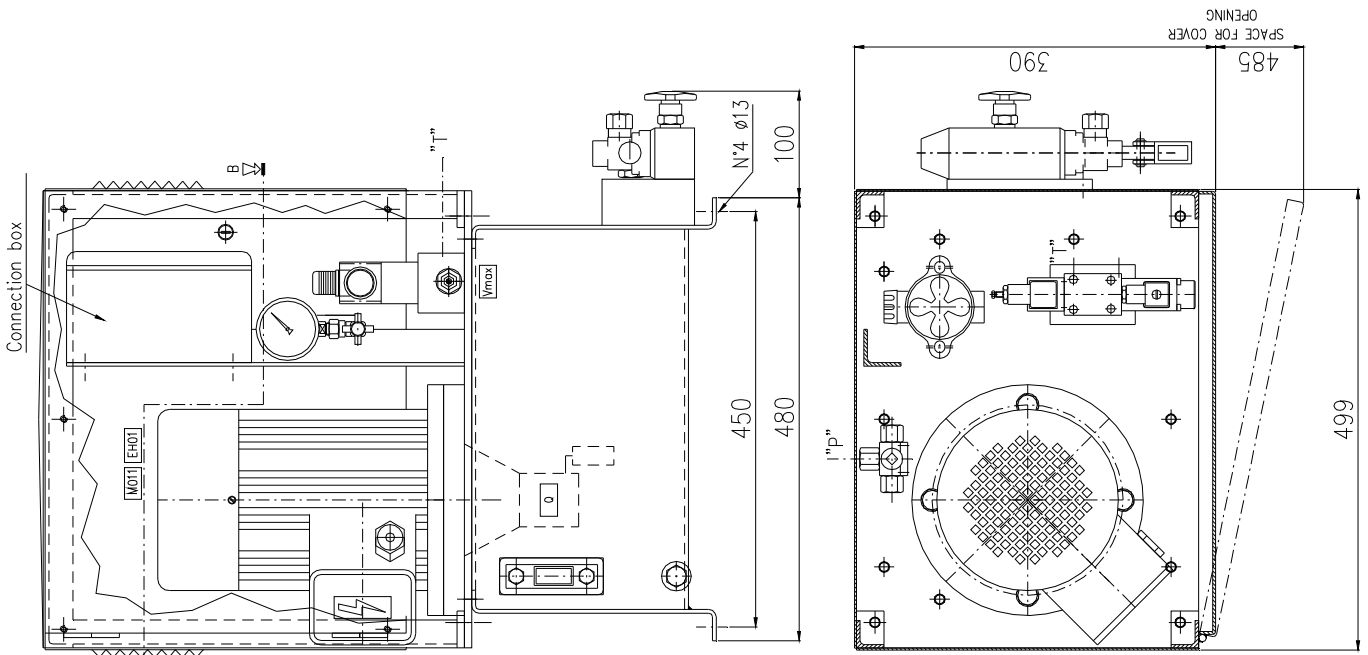

WEIGHT 80 kg
without oil

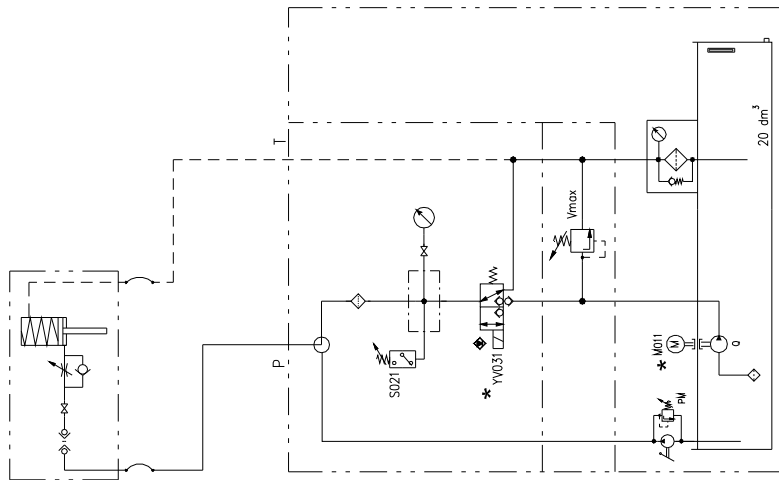

SEZ B-3

TYPE	* M011 (kW)	Q (l/min)	Vmax (MPa)	S021 (MPa)	*	P-T	OPENING TIMES (s) (suitable for one brake)			
							TP-00-01	TP-10-01	TP-20-01	TP-30-01
SCI-TP20-5-PM-01	1.5 400V-50Hz	5	21	19-18	24V DC-30W	G3/8"	2	2.5	4	5.5
SCI-TP20-7.5-PM-01	3 400V-50Hz	7.5	21	19-18	24V DC-30W	G3/8"	1.4	1.7	2.7	3.7
* = OTHER FEEDING TENSIONS ON REQUEST							OTHER TIMES ON REQUEST			



Rima S.r.l.
Via Fermi 255 – 21042 Caronno Pertusella (Va) Italy
Phone: +39 02 9650694 – Fax +39 02 9657860
E-mail: rima@rimagroup.com



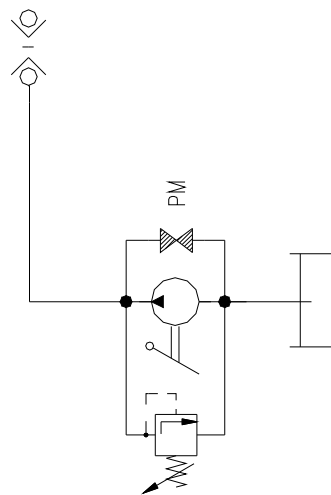
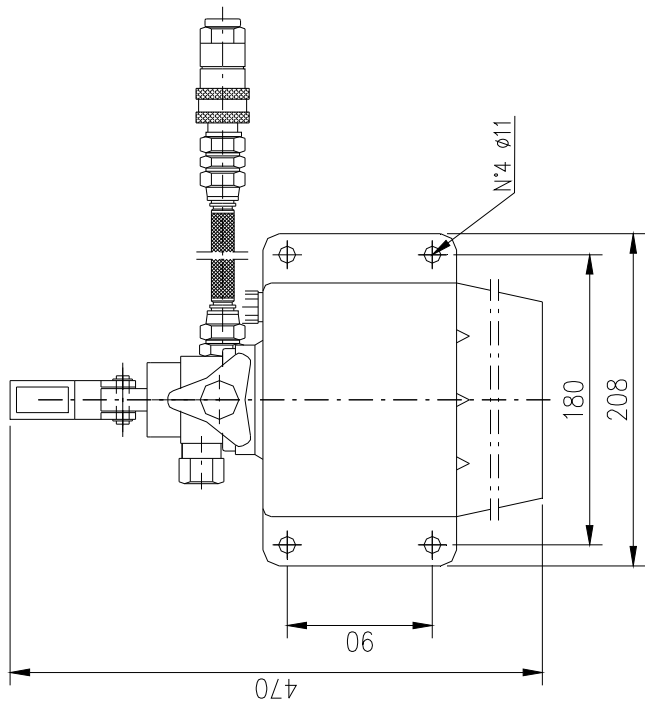
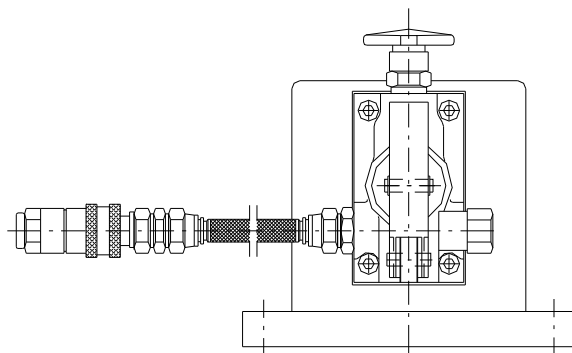
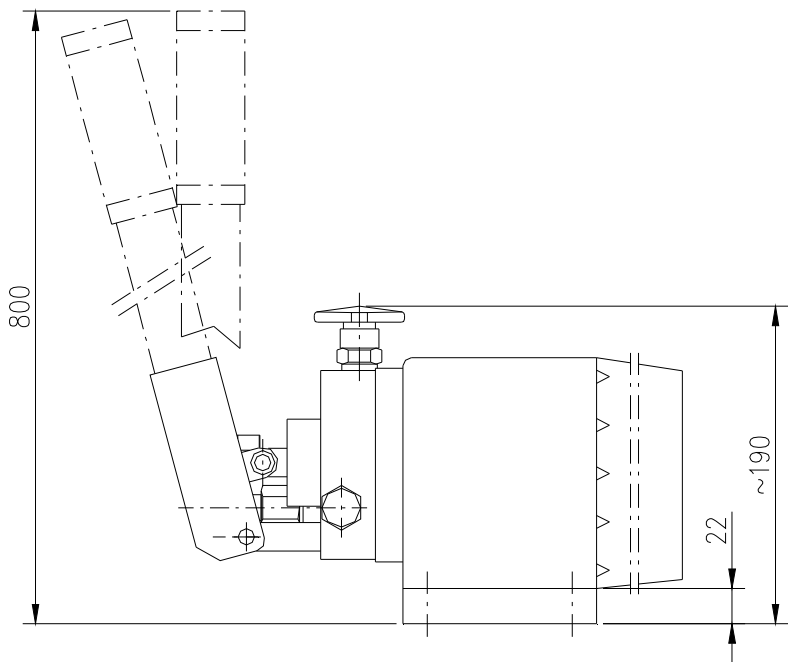

SCI-PM-01





via Bettola 32
I-20092 Cinisello Balsamo (MI)
Tel.: 02-66 05 3.1
Fax: 02-66 01 28 02

/MG File: Rima-02

Cinisello, 02/05/98

TEST REPORT

Customer: RIMA S.r.l.
STEMMAN-TECHNIK GmbH

Object: Brakes Type R2291 and R2271

N° of order: 100987 (TÜV Italy)

Technical files: See Annex

Site of testing activity: Caronno Pertusella (Varese, Italy)

Date of test: 2/5/1998

Test description: The test was carried out with knurled sliding for brakes type R 2271, in order to have the same specific pressure of the sliding type R2291.
The minimum friction coefficient was recorded for each condition of rail's surface state.
Values are shown in the schedule.
See annex for more informations.
In addition the rail clamp was pushed as far as the rail clamp started to slip (only by greasy rail).

Type of knurled sliding (R2271)	State of side surface of rail	Radial force F ₁ [kN]	Axial force F ₂ [kN]	Friction coefficient $\mu = F_2 / 2 * F_1$	Slipping force F ₂ [kN]
□ 2 x 2 mm	dry	99.6	100	> 0.5	//
□ 2 x 2 mm	wet	99.6	100	> 0.5	//
□ 2 x 2 mm	greasy	99.6	100	> 0.5	119 ($\mu \approx 0.59$)
□ 2,3 x 2,3 mm	dry	95.2	103	> 0.5	//
□ 2,3 x 2,3 mm	wet	95.2	103	> 0.5	//
□ 2,3 x 2,3 mm	greasy	95.2	103	> 0.5	113 ($\mu \approx 0.54$)

Ing. Giorgio Mazzoni

TÜV ITALIA S.R.L.
Società del Gruppo TÜV Süddeutschland
Amministratore Delegato: Roberto Majocchi - Sede legale: Via Bettola 32 - 20092 Cinisello Balsamo (MI)
Capitale sociale Lit. 850.000.000 interamente versato - Cod. Fisc. 08922920155 - P. IVA 02055510966 - Registro delle imprese di Milano (Trib. Monza) No. 273786 - R.E.A. 1255140

Rima S.r.l.
Via Fermi 255 - 21042 Caronno Pertusella (Va) Italy
Phone: +39 02 9650694 - Fax +39 02 9657860
E-mail: rima@rimagroup.com



WWW.RIMAGROUP.COM

SCHEMA ELETTRICO PER 2 CENTRALINE E 4 FRENI
ELECTRICAL DIAGRAM FOR 2 HYDRAULIC UNITS AND 4 BRAKES
SCHÉMA ÉLECTRIQUE POUR 2 CENTRALES HYDRAULIQUES ET 4 FREINS
ELEKTRISCHE SCHALTPLAN FÜR 2 HYDRAULIC AGGREGATE UND 4 BREMSEN

DATA CONSEGNA DELIVERY DATE DONNÉE DE CONSIGNÉ LIEFERDATUM		TENSIONE DI ESERCIZIO / RATING VOLTAGE TENSION DE MARCHÉ / BETRIEBSSTROMUNG	GRADO PROTEZIONE / PROTECT. DEGREE DEGRÉ DE PROTECTION / SCHUTZ-GRAD	NORME CEI-EN / CEI-EN STANDARDS RÉGLE CEI-EN / CEI-EN VORSCHRIFT
POTENZA MAX ASSORBITA MAX RATING POWER PUISSANCE MAXI MAX BETRIEBSKRAFT	3 kW	400 Vac	55	60439-1
CORR. MAX SPUNTO MAX PEAK CURRENT COURANT DE POINTE MAXI MAX SPITZESTROM	20 A	TENSIONE COMANDI / CONTROL CIRCUITS VOLTAGE TENSION AUXILIAIRE / STEUERSPANNUNG	<small>In base al DPR 547/55, Dlgs 626/94, Dlgs 494 Norma CEI EN 50110-1, Norma CEI EN 11-27 - I lavori elettrici all'interno dell'apparecchiatura di comando possono essere eseguiti solo da PES o da PAV con attestato di idoneità (PES = persona esperta, PAV = persona avvertita) Tale idoneità sarà confermata dal preposto ai lavori elettrici. In compl. with DPR 547/55, Dlgs 626/94 CEI EN 50110-1, CEI 11-27 specifications, electrical works inside control equipm. must be performed only by EP or WP with techn. degree (EP = expert person, WP = warned person). This feature will be checked by an electrical maintenance division chief: Conformément à DPR 547/55, Dlgs 626/94, Dlgs 494, Règle CEI EN50110-1 - CEI 11-27, les travaux électriques à l'intérieur de l'appareillage de commande doivent être exécutés seulement de PE ou PAV (PE=personne d'expertise, PAV= personne avvertie) avec le degré technique Ces possibilités seront vérifiées par un chef de division de entretien électrique Gemäß DPR 547/55, Dlgs 626/94, Dlgs 494 Vorschrift CEI EN 50110-1 - CEI 11-27 muß innere ElektrosteuerungseinrichtungArbeiten von AP oder von GP mit technischem Grad (AP=Ausgebildeter Person, GP=Gewarmer Person) durchgeführt werden. Diese Eigenschaft muß durch die Elektroarbeiten meister überprüft werden</small>	
C.D.T.% MAX. CONSENTITA MAX ADMITTED VOLTAGE DROP % CHUTE DE TENSION ADMISE % MAXI MAX ZUGEL SPANNUNGSABFALL %	5	24 Vac		
SEZIONE RACCOMANDATA RECOMMENDED WIRING SECTION SECTION RECOMMANDÉE EMPFOHLEN KABELANTEIL	2,5 mm ²	TENSIONE SEGNALI / SIGNALS VOLTAGE TENSION SIGNALX / SIGNALESSTROMUNG		
CORRENTE DI CORTO C.T.O MAX SHORT CIRCUIT CURRENT COURANT DE COURT CIRCUIT MAX KURZSCHLUSSSTROM	17 kA	24 Vac		

 I - 21042 - Caronno P.lia (VA) - Italy Via E. Fermi, 255 Tel. +39-2-9650694 Fax. +39-2-9657860 Web: http://www.rimagroup.com	DESCRIZIONE / DESCRIPTION DESCRIPTION / BESCHREIBUNG	COMMESSA / JOB TRAVAIL / BESTELLUNG	DISEGNATORE / DRAWN BY DESSINATEUR / ZEICHNER	MODIFICHE / UPGRADE MISE A JOUR / PRÜFUNG	DISEGNO N° / DRAWING N° DESSIN N° / ZEICHNUNG N°	TOT. FOGLI N° TOT. SHEETS N° TOT. FEUILLES N° GES. BLÄTTERN N°
	COPERTINA FRONT PAGE PAGE DE GARDE VORDERSEITE		E.C.	DATA / DATE / DATE / DATUM 21-06-2007		SCE-TP-01

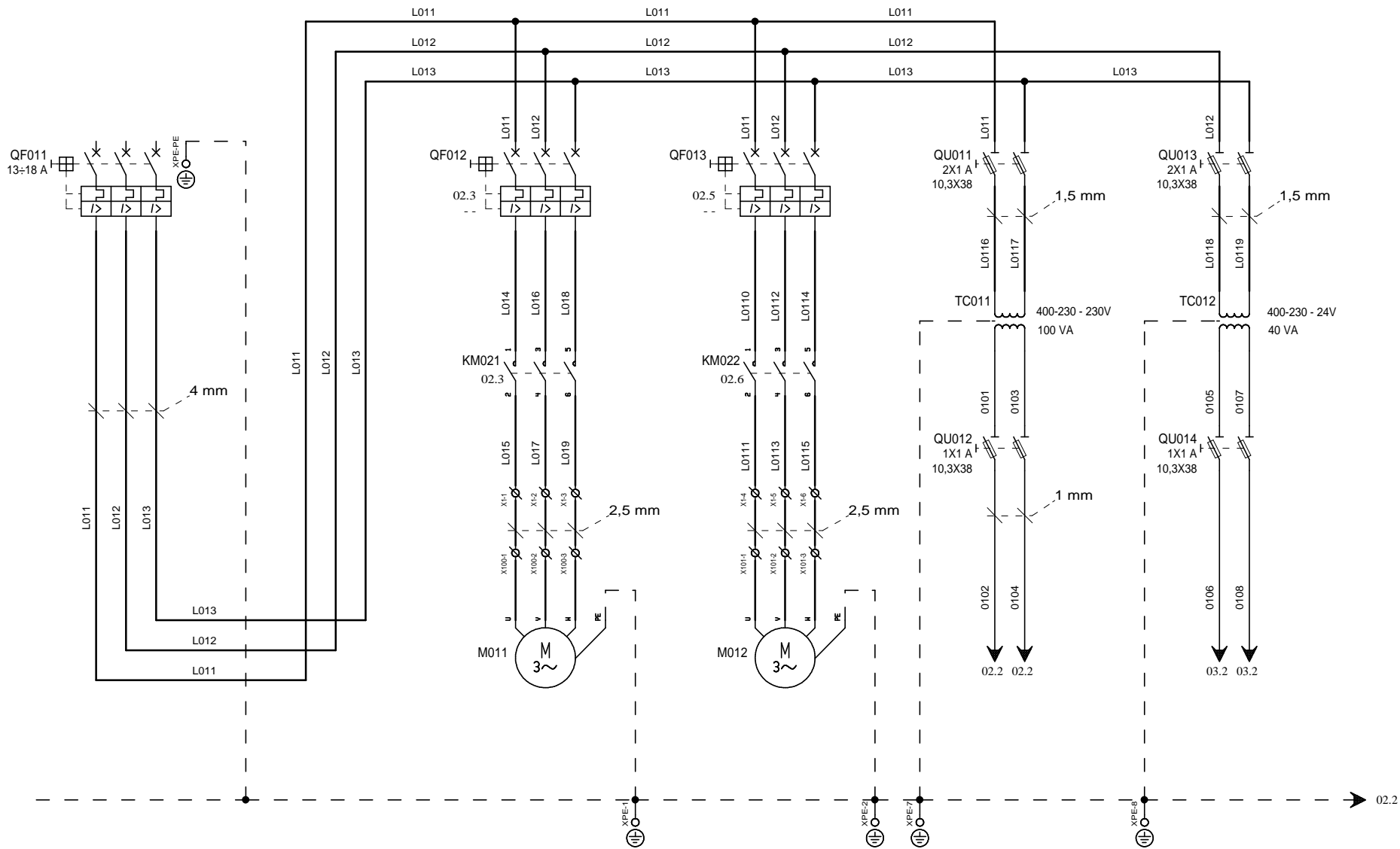

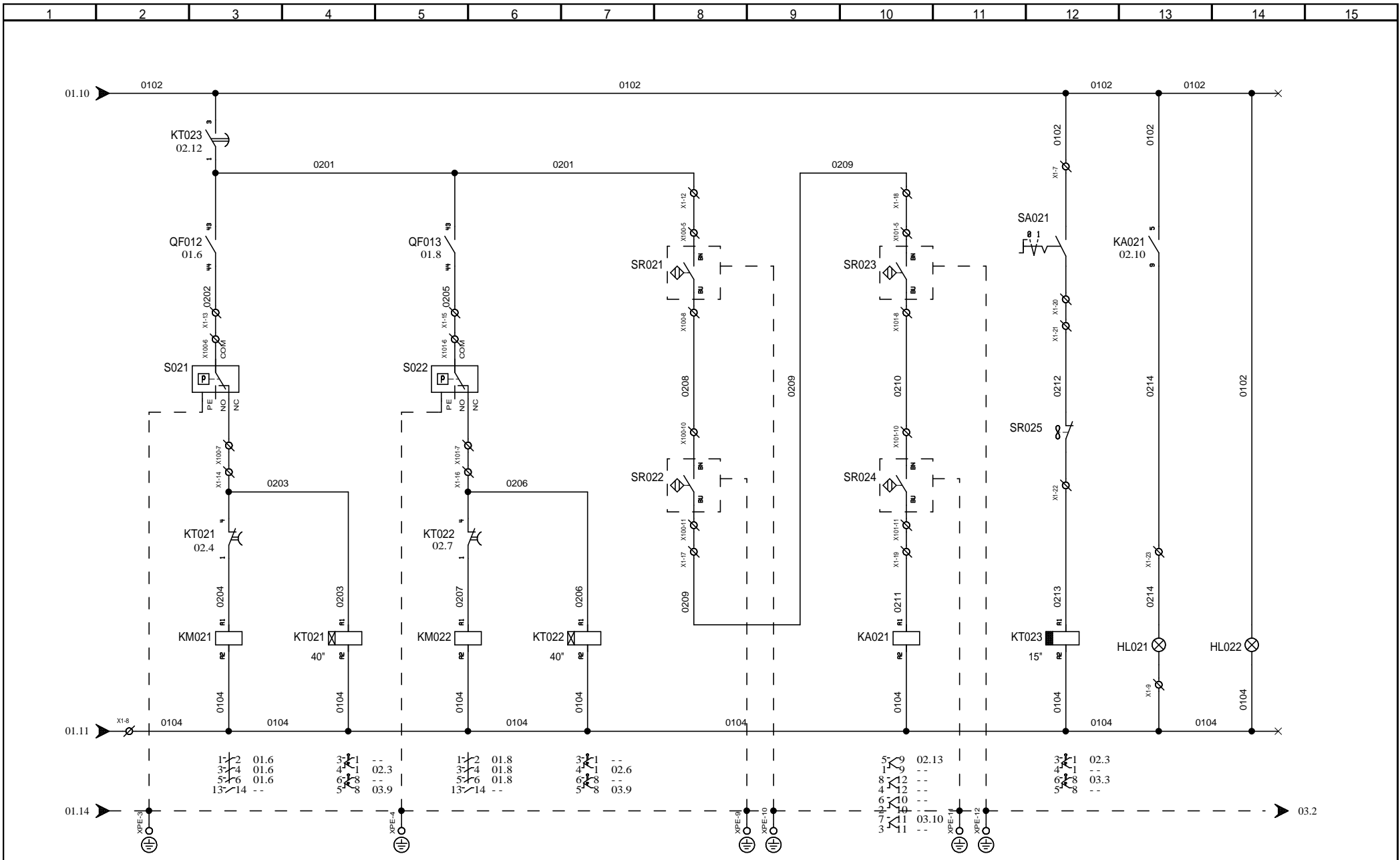

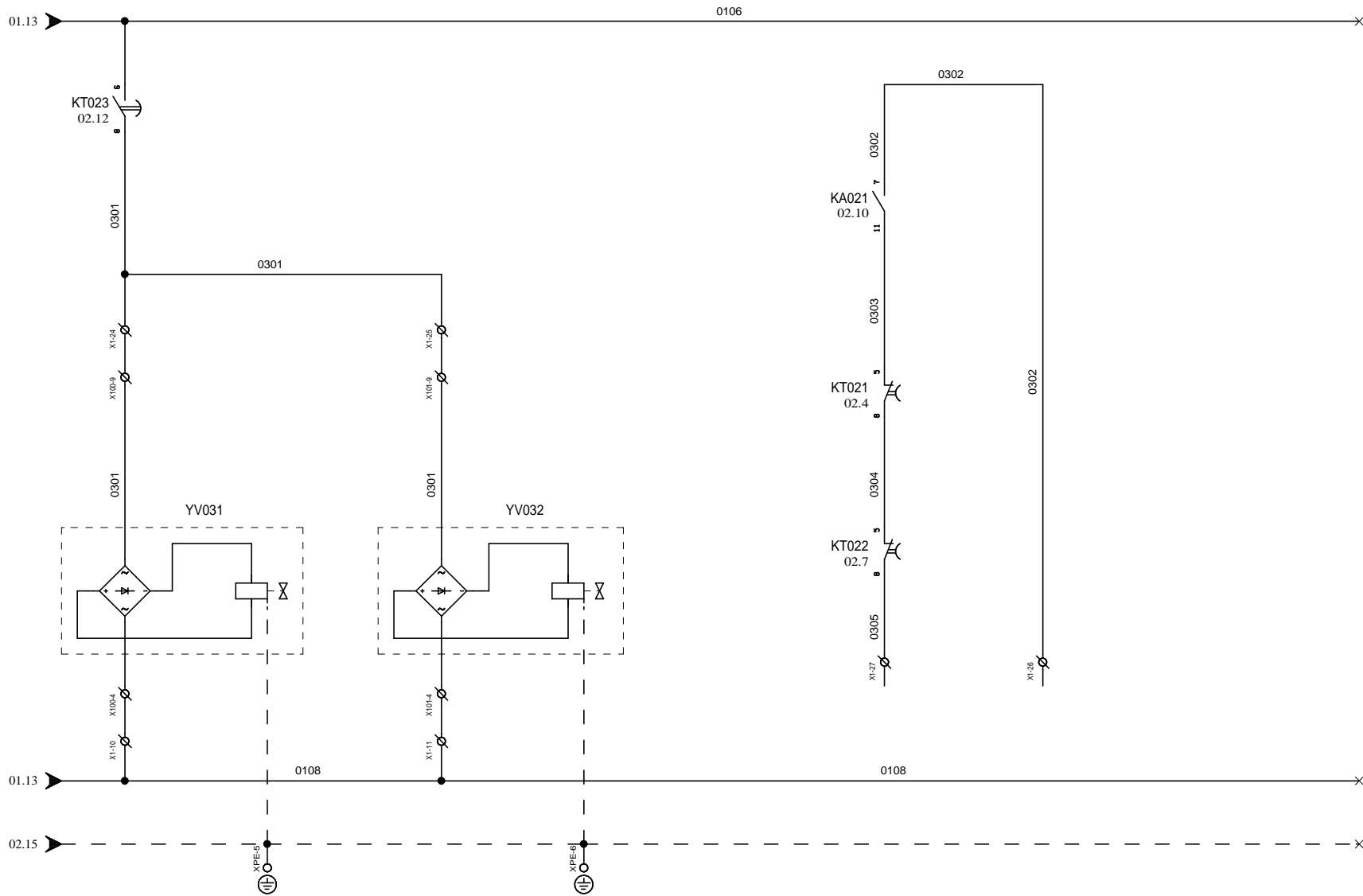

 <p>1 - 21042 - Caronno P.lia (VA) - Italy Via E. Fermi, 255 Tel. +39-2-9650694 Fax. +39-2-9657860 Web: http://www.rimagroup.com</p>	<p>DESCRIZIONE / DESCRIPTION DESCRIPTION / BESCHREIBUNG</p> <p>CIRCUITI AUSILIARI AUXILIARY CIRCUITS CIRCUITS AUXILIAIRES HILFSSTROMKREISE</p>	<p>COMMESSA / JOB TRAVAIL / BESTELLUNG</p>	<p>DISEGNATORE / DRAWN BY DESSINATEUR / ZEICHNER</p> <p>E.C.</p>	<p>MODIFICHE / UPGRADE MISE A JOUR / PRÜFUNG</p>	<p>DISEGNO N° / DRAWING N° DESSIN N° / ZEICHNUNG N°</p> <p>SCE-TP-01</p>	<p>TOT.FOGLI N° TOT.SHEETS N° TOT.FEUILLES N° GES.BLÄTTERN N°</p> <p>6</p>
			<p>DATA / DATE / DATE / DATUM</p> <p>21-06-2007</p>			<p>PAGINA PAGE FEUILLE BLATT</p> <p>02</p>

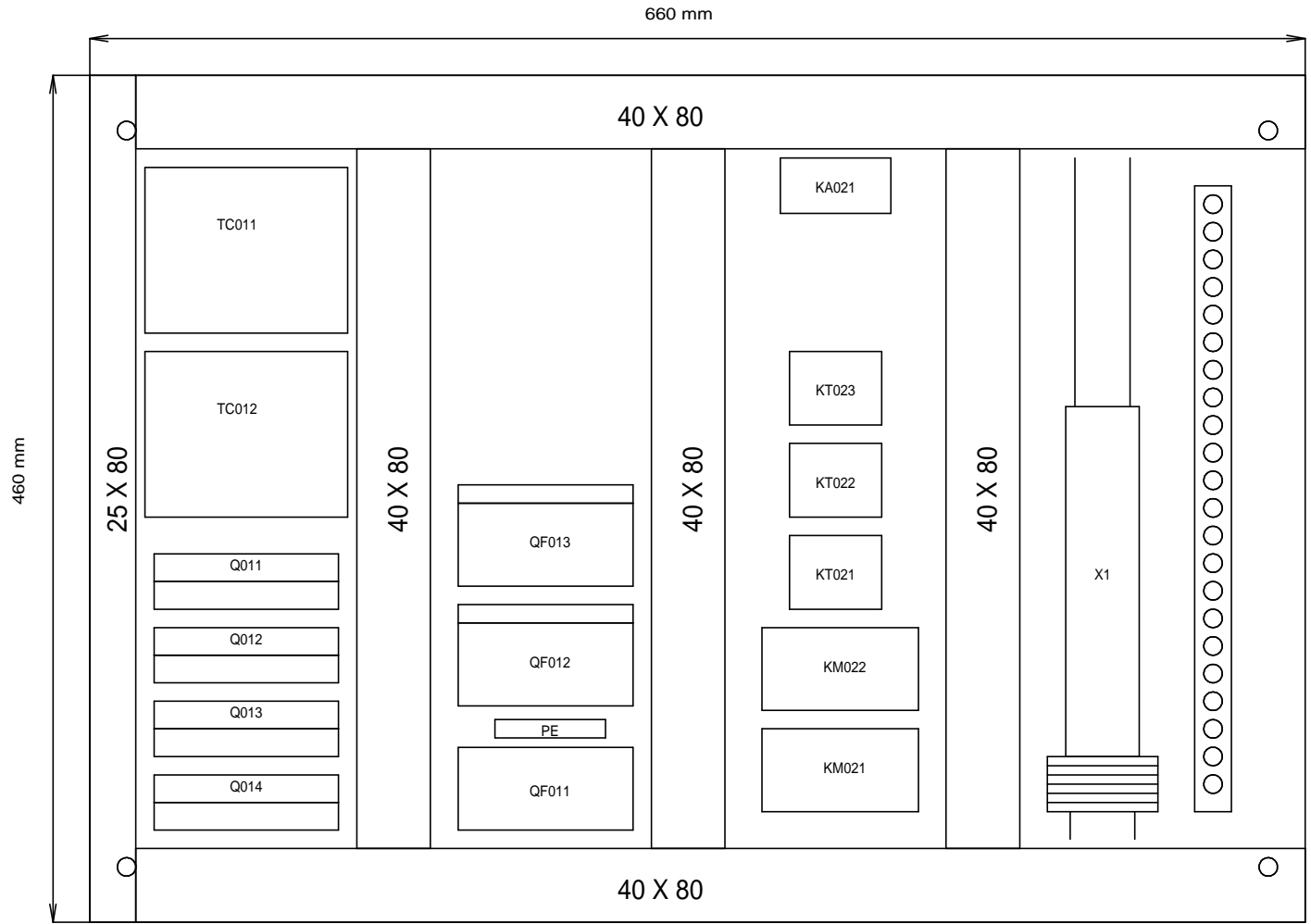

 <p>1 - 21042 - Caronno P.lia (VA) - Italy Via E. Fermi, 255 Tel. +39-2-9650694 Fax. +39-2-9657860 Web: http://www.rimagroup.com</p>	DESCRIZIONE / DESCRIPTION DESCRIPTION / BESCHREIBUNG	COMMESSA / JOB TRAVAIL / BESTELLUNG	DISEGNATORE / DRAWN BY DESSINATEUR / ZEICHNER	MODIFICHE / UPGRADE MISE A JOUR / PRÜFUNG	DISEGNO N° / DRAWING N° DESSIN N° / ZEICHNUNG N°	TOT.FOGLI N° TOT.SHEETS N° TOT.FEUILLES N° GES.BLÄTTERN N°
	ELETTROVALVOLE E SEGNALI ELECTROVALVES AND SIGNALS ÉLECTROVANNES ET SIGNALISATIONS ELEKTROVENTILE UND SIGNALE			E.C. DATA / DATE / DATE / DATUM 21-06-2007		SCE-TP-01



 1 - 21042 - Caronno P.lia (VA) - Italy Via E. Fermi, 255 Tel. +39-2-9650694 Fax. +39-2-9657860 Web: http://www.rimagroup.com	DESCRIZIONE / DESCRIPTION DESCRIPTION / BESCHREIBUNG	COMMESSA / JOB TRAVAIL / BESTELLUNG	DISEGNATORE / DRAWN BY DESSINATEUR / ZEICHNER	MODIFICHE / UPGRADE MISE A JOUR / PRÜFUNG	DISEGNO N° / DRAWING N° DESSIN N° / ZEICHNUNG N°	TOT.FOGLI N° TOT.SHEETS N° TOT.FEUILLES N° GES.BLÄTTERN N°	
	DISPOSIZIONE PIASTRA COMPONENTI ELECTRIC PANEL LAYOUT IMPLANTATION PLATINE ARMOIRE SCHALTSCHRANK INNENEINRICHTUNG			E.C. DATA / DATE / DATE / DATUM 21-06-2007		SCE-TP-01	6
							PAGINA PAGE FEUILLE BLATT 04
						SEGUE NEXT SUIVANT NÄCHSTE 05	

QF011	INTERRUTTORE GENERALE	MAIN SWITCH	DISJONCTEUR PRINCIPAL	HAUPTSCHALTER
QF012	PROTEZIONE MOTORE POMPA CENTRALINA 1	HYDRAULIC UNIT 1 MOTOR PROTECTIVE SWITCH	DISJONCTEUR MOTEUR ÉQUIPEMENT HYDRAULIQUE 1	HYDRAULISCHE GERÄT 1 MOTORSCHUTZSCHALTER
QF013	PROTEZIONE MOTORE POMPA CENTRALINA 2	HYDRAULIC UNIT 2 MOTOR PROTECTIVE SWITCH	DISJONCTEUR MOTEUR ÉQUIPEMENT HYDRAULIQUE 2	HYDRAULISCHE GERÄT 2 MOTORSCHUTZSCHALTER
QU011	FUSIBILE PROTEZIONE TRASFORMATORE CIRCUITI AUSILIARI	AUXILIARY CIRCUITS TRANSFORMER PROTECTION FUSE	COUPE-CIRCUIT PROTECTION TRANSFO CIRCUITS AUXILIAIRES	HILFSSTROMKREISETRAFO SCHUTZ SICHERUNGSLASTTRENNER
QU013	FUSIBILE PROTEZIONE TRASFORMATORE ELETTROVALVOLE	ELECTROVALVES TRANSFORMER PROTECTION FUSE	COUPE-CIRCUIT PROTECTION DU TRANSFO ELECTROVANNES	ELEKTROVENT. STROMKREISETRAFO SCHUTZ SICHERUNGSLASTTR.
TC011	TRASFORM. ALIMENTAZIONE CIRCUITI AUSILIARI	AUXILIARY CIRCUITS SUPPLY TRANSFORMER	TRANSFORMATEUR ALIMENTATION CIRCUITS AUXILIAIRES	HILFSKREISE STROMVERSORGUNG TRAFO
TC012	TRASFORM. ALIMENTAZIONE ELETTROVALVOLE	ELECTROVALVES SUPPLY TRANSFORMER	TRANSFORMATEUR ALIMENTATION ELECTROVANNES	ELEKTROVENTILE STROMVERSORGUNG TRAFO
QU012	FUSIBILE PROTEZIONE LINEA AUSILIARI	AUXILIARY CIRCUITS LINE PROTECTION FUSE	COUPE-CIRCUIT PROTECTION LIGNE AUXILIAIRES	HILFSKREISELEITUNG SCHUTZ SICHERUNGSLASTTRENNER
QU014	FUSIBILE PROTEZIONE LINEA ELETTROVALVOLE	ELECTROVALVES LINE PROTECTION FUSE	COUPE-CIRCUIT PROTECTION LIGNE ELECTROVANNES	ELEKTROVENTILE LEITUNG SCHUTZ SICHERUNGSLASTTRENNER
M011	MOTORE POMPA CENTRALINA 1	HYDRAULIC UNIT 1 PUMP MOTOR	MOTEUR POMPE ÉQUIPEMENT HYDRAULIQUE 1	HYDRAULISCHE GERÄT 1 PUMPE MOTOR
M012	MOTORE POMPA CENTRALINA 2	HYDRAULIC UNIT 2 PUMP MOTOR	MOTEUR POMPE ÉQUIPEMENT HYDRAULIQUE 2	HYDRAULISCHE GERÄT 2 PUMPE MOTOR
KM021	CONTATTORE MOTORE POMPA CENTRALINA 1	HYDRAULIC UNIT 1 PUMP MOTOR CONTACTOR	CONTACTEUR MOTEUR POMPE ÉQUIPEMENT HYDRAULIQUE 1	HYDRAULISCHE GERÄT 1 PUMPE MOTOR SCHUTZ
KM022	CONTATTORE MOTORE POMPA CENTRALINA 2	HYDRAULIC UNIT 2 PUMP MOTOR CONTACTOR	CONTACTEUR MOTEUR POMPE ÉQUIPEMENT HYDRAULIQUE 2	HYDRAULISCHE GERÄT 2 PUMPE MOTOR SCHUTZ
KT021	TEMPORIZZ. SICUREZZA DISINSERZIONE MOTORE CENTRALINA 1	HYDRAULIC UNIT 1 PUMP MOTOR DISABLING SAFETY TIMER	TEMPORISATEUR SECURITÉ ARRÊT ÉQUIPEMENT HYDRAULIQUE 1	HYDRAULISCHE GERÄT 1 ANSCHLAG SCHUTZ ZEITRELAIS
KT022	TEMPORIZZ. SICUREZZA DISINSERZIONE MOTORE CENTRALINA 2	HYDRAULIC UNIT 2 PUMP MOTOR DISABLING SAFETY TIMER	TEMPORISATEUR SECURITÉ ARRÊT ÉQUIPEMENT HYDRAULIQUE 2	HYDRAULISCHE GERÄT 2 ANSCHLAG SCHUTZ ZEITRELAIS
KA021	RELÉ CONSENSO TRASLAZIONE PER TENAGLIE APERTE	OPEN CLAMPS TRANSLATION ENABLING RELAY	RELAIS CONSENTEMENT TRANSLATION AVEC PINCES OUVERTES	RELAIS ÜBERTRAGUNG ERMÖGLICHKEIT MIT ÖFFNEN ZANGEN
S021	PRESSOSTATO MANTENIMENTO TENAGLIE APERTE 1	OPEN CLAMPS HOLDING PRESSURE SWITCH 1	CAPTEUR DE PRESSION DE MAINTIEN PINCES OUVERTES 1	ZANGENÖFFNUNGDAUER 1 DRUCKSCHALTER
S022	PRESSOSTATO MANTENIMENTO TENAGLIE APERTE 2	OPEN CLAMPS HOLDING PRESSURE SWITCH 2	CAPTEUR DE PRESSION DE MAINTIEN PINCES OUVERTES 2	ZANGENÖFFNUNGDAUER 2 DRUCKSCHALTER
KT023	TEMPORIZZATORE SICUREZZA CICLO	CYCLE SAFETY TIMER	TEMPORISATEUR POUR SECURITÉ CYCLE	KREISLAUF SCHUTZ ZEITRELAIS
SR021	FC INDUTTIVO TENAGLIE APERTE CONSENSO TRASLAZIONE 1	OPEN CLAMPS TRANSLATION ENABLING INDUCTIVE SWITCH 1	FDC INDUCTIF PINCES OUVERTES ET CONSENT. TRANSLATION 1	ÜBERTRAG. ERMÖGLICH.- ÖFFNEN ZANGEN 1 NÄHERUNGSINITIAT.
SR022	FC INDUTTIVO TENAGLIE APERTE CONSENSO TRASLAZIONE 1	OPEN CLAMPS TRANSLATION ENABLING INDUCTIVE SWITCH 1	FDC INDUCTIF PINCES OUVERTES ET CONSENT. TRANSLATION 1	ÜBERTRAG. ERMÖGLICH.- ÖFFNEN ZANGEN 1 NÄHERUNGSINITIAT.
SR023	FC INDUTTIVO TENAGLIE APERTE CONSENSO TRASLAZIONE 2	OPEN CLAMPS TRANSLATION ENABLING INDUCTIVE SWITCH 2	FDC INDUCTIF PINCES OUVERTES ET CONSENT. TRANSLATION 2	ÜBERTRAG. ERMÖGLICH.- ÖFFNEN ZANGEN 2 NÄHERUNGSINITIAT.
SR024	FC INDUTTIVO TENAGLIE APERTE CONSENSO TRASLAZIONE 2	OPEN CLAMPS TRANSLATION ENABLING INDUCTIVE SWITCH 2	FDC INDUCTIF PINCES OUVERTES ET CONSENT. TRANSLATION 2	ÜBERTRAG. ERMÖGLICH.- ÖFFNEN ZANGEN 2 NÄHERUNGSINITIAT.
SA021 *	COMANDO INIZIO CICLO	START CYCLE CONTROL	CONTROLE MARCHE DU CYCLE	KREISLAUF ANFANG
SR025 *	ANEMOMETRO	AIR-SPEED METER	ANÉMOMÈTRE	LUFTGESCHWINDIGKEITMESSER
HL021 *	SEGNALAZIONE CONSENSO TRASLAZIONE	TRANSLATION ENABLING SIGNAL	SIGNALISATION CONSENTEMENT TRANSLATION	ÜBERTRAGUNG ERMÖGLICHKEIT SIGNALISIERUNG
HL022 *	SEGNALAZIONE PRESENZA TENSIONE	POWER ON SIGNAL	SIGNALISATION DE TENSION EN LIGNE	SPANNUNG EIN SIGNALISIERUNG
YV031	ELETTROVALVOLA CENTRALINA 1	HYDRAULIC UNIT 1 ELECTROVALVE	ELECTROVANNE ÉQUIPEMENT HYDRAULIQUE 1	HYDRAULISCHE GERÄT 1 ELEKTROVENTIL
YV032	ELETTROVALVOLA CENTRALINA 2	HYDRAULIC UNIT 2 ELECTROVALVE	ELECTROVANNE ÉQUIPEMENT HYDRAULIQUE 2	HYDRAULISCHE GERÄT 2 ELEKTROVENTIL
*	ESCLUSO DALLA FORNITURA DEL QUADRO DI COMANDO	NOT SUPPLIED WITH THE CONTROL EQUIPMENT	PAS EN LA FOURNITURE DU ÉQUIPEMENT DE CONTROLE	NICHT GELIEFERT MIT DAS SCHALTGERÄT

 <p>1 - 21042 - Caronno P.lia (VA) - Italy Via E. Fermi, 255 Tel. +39-2-9650694 Fax. +39-2-9657860 Web: http://www.rimagroup.com</p>	DESCRIZIONE / DESCRIPTION DESCRIPTION / BESCHREIBUNG COMPONENTI E LORO FUNZIONI COMPONENTS AND FUNCTIONS COMPOSANTS ET FONCTIONNES BAUELEMENTE UND BETRIEBSFUNKTION	COMMESSA / JOB TRAVAIL / BESTELLUNG	DISEGNATORE / DRAWN BY DESSINATEUR / ZEICHNER E.C.	MODIFICHE / UPGRADE MISE A JOUR / PRÜFUNG	DISEGNO N° / DRAWING N° DESSIN N° / ZEICHNUNG N° SCE-TP-01	TOT.FOGLI N° TOT.SHEETS N° TOT.FEUILLES N° GES.BLÄTTERN N° 6
			DATA / DATE / DATE / DATUM 21-06-2007			PAGINA PAGE FEUILLE BLATT 05